

R S L

Refreshment Systems Ltd.

Cleaning Guide

Bag & Overstrom B4 (Sport)



Contact us

www.refreshmentsystems.co.uk

For Service:
service@refreshmentsystems.co.uk
01274 750 008

For Ingredients:
ingredients@refreshmentsystems.co.uk
01226 720 482

This cleaning guide is for **advice only**

Please refer to the operative manual for complete safety information and instruction when considering any maintenance on the machine.

Maintenance

Isolation & Removal

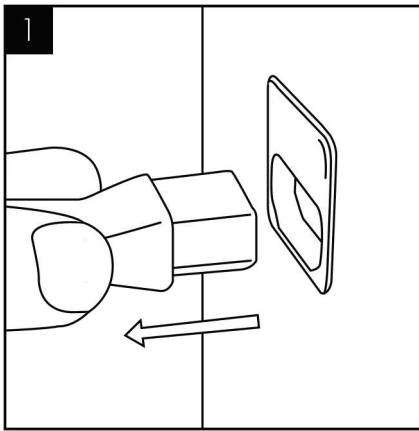

Please make sure the machine is completely disconnected from electricity before carrying out any maintenance work.

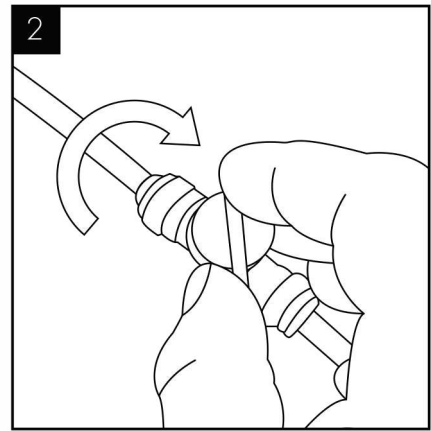

Turn off the water supply.

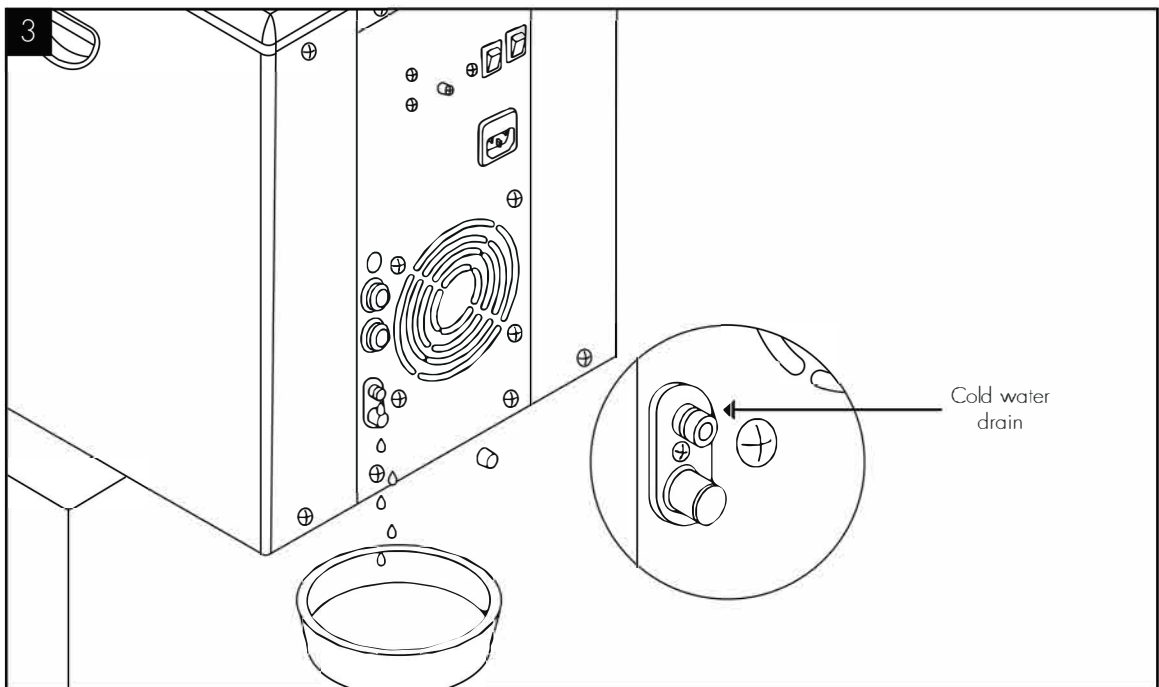

To drain the Direct Chill tank, remove the cap on the back of the machine. We recommend it is refitted immediately upon draining being completed.

Sanitisation Guide

NOTE: Before beginning the sanitation process please ensure that water is turned off at the mains and refer to the MSDS document for further information. Use bioguard hand gel and ensure gloves are worn.

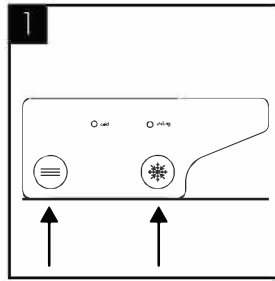

1 Briefly press cold/ambient dispense buttons to release internal water pressure from the machine.

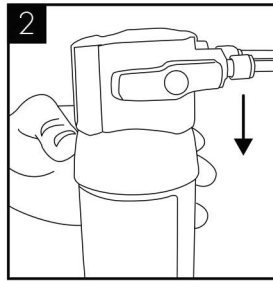

2 Remove the existing filter.

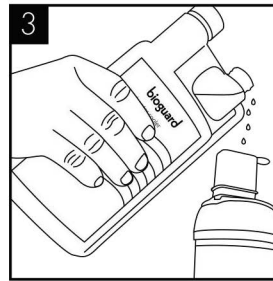

3 Add 25 ml of Bioguard Internal Sanitisation fluid to a clean and empty service filter cartridge.

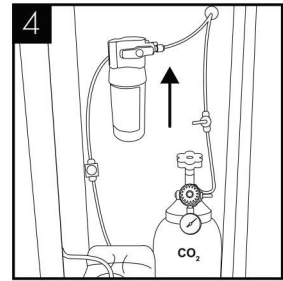

4 Connect to machine.

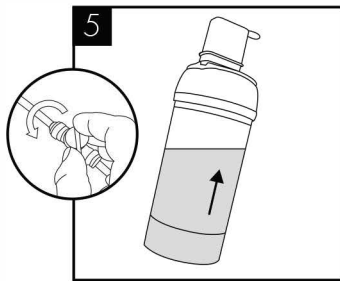

5 Turn on incoming water, allow service cartridge/doser to fill.

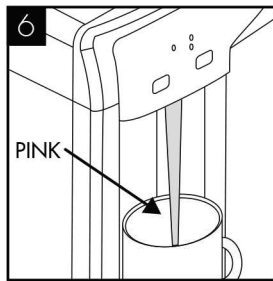

6 Dispense water using the cold button until the water appears pink. Briefly press the ambient button too. Repeat with sparkling button if present.

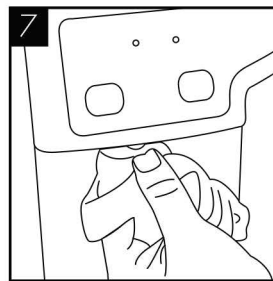

7 Leave the solution inside machine for sanitisation to take effect (minimum 5 minutes) while thoroughly cleaning the machine externally, pay particular attention to the dispense faucet and button controls.

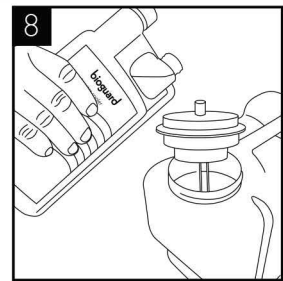

8 Remember to include the drip tray. If a Waste Overflow System is fitted, empty this and flush through with a small amount of sanitisation fluid if needed.

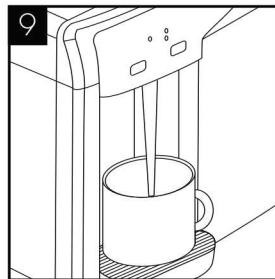

9 When the external cleaning (minimum 5 minutes) is completed, flush the machine using the cold button with clean water until the dispense water runs clear. Repeat briefly with the ambient button.

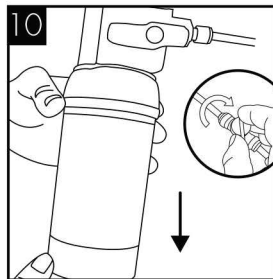

10 Turn off water and remove the service filter. Retain service filter for reuse.

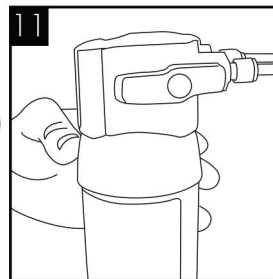

11 Fit new filter. Turn on incoming water supply.

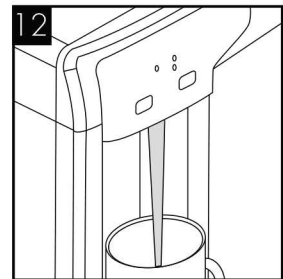

12 Pre-flush the new filter to waste using the ambient button (and sparkling button if present) until the water appears clear and is free of air. Flush through a small amount of water to check all functions.

Leak Detection (power cut off) -Sparkling Variants Only Enhanced Leak Detection (Flood prevention) Available as Optional Extra.

NOTE: If this machine is equipped with a leak detection device. When leaking is detected the dispense operation will be cut off automatically.

To reset:

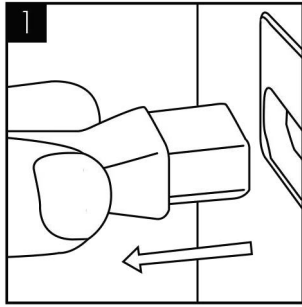

Unplug the machine.

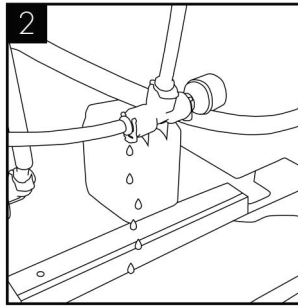

Locate the source of leakage and rectify.

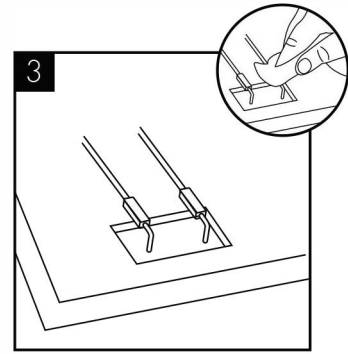

Locate the detection probe which can be found in the bottom front left hand corner. Dry the probes and internal area with a dry cloth.

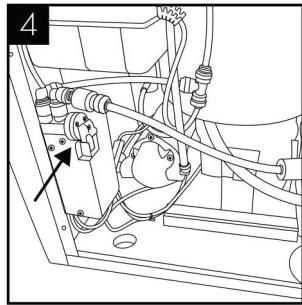

If enhanced Leak Detector is fitted as optional extra: locate the Leak Detector valve.

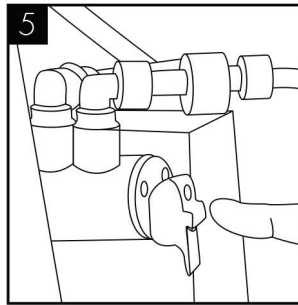

Reset the red lever (push it in).

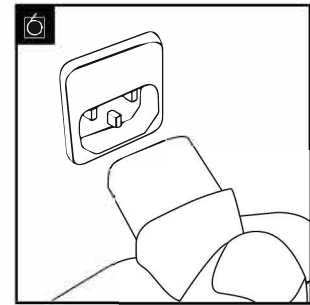

Reconnect the power to machine and test operation.

If leak detector is fitted as optional extra, reset the red lever (push it in)

Emptying the Carbonation Tank

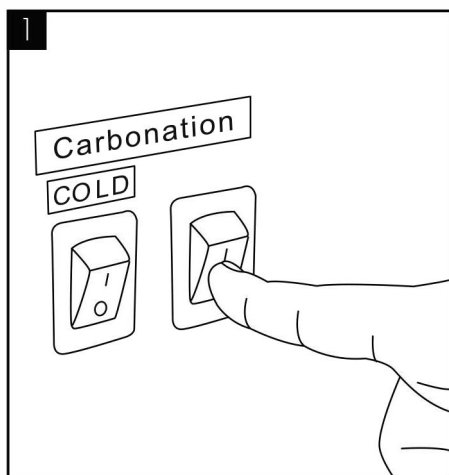

Switch off the Carbonation System switch on the back of the unit.

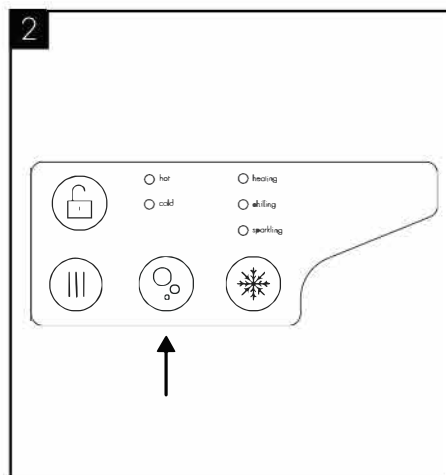

Press and hold the Sparkling water dispense button until all water is expelled.

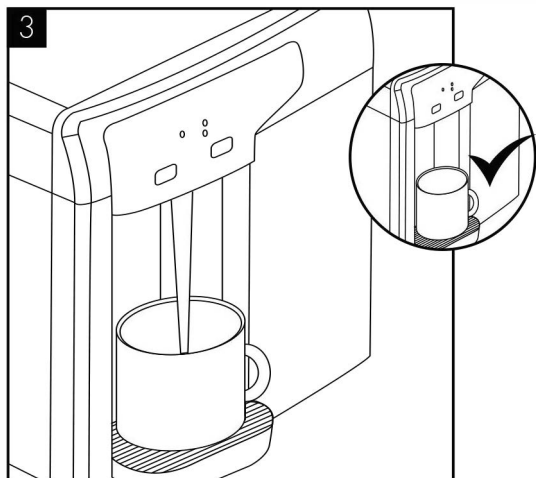

The tank is empty of sparkling water when only CO₂ is being released.

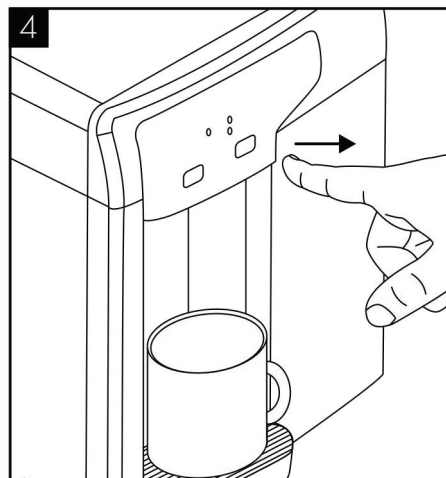

Ensure to release the Sparkling water button and take care to avoid releasing excess amounts of CO₂ gas.